

# Design and Application Prototype of soft starting Three-Phase AC Motor by Using Analog Electronics Control for Teaching Aids of Power Electronics Practice

Effendi <sup>a,1,\*</sup>, Zakwansyah <sup>a,2</sup>

<sup>a</sup> Aceh Polytechnic, Jl. Politeknik Aceh No.1, Pango Raya Ulee Kareng-Banda Aceh 23119, Indonesia

<sup>1</sup> effendi@politeknikaceh.ac.id\*; <sup>2</sup> zakwansyah@politeknikaceh.ac.id

\*corresponding author

## ARTICLE INFO

## ABSTRACT

*Article history:*  
Published

*Keywords:*  
three-phase AC voltage regulator  
three-phase motor soft start  
SCR triggering delay angle  
IC LM324  
Vrms voltage

In general, palm oil processing factories, from fresh fruit bunches to Crude Palm Oil, require three-phase electric motors to drive or rotate it. The problems that often arise when using three-phase electric motors simultaneously in large numbers will result in very large surges in the electric current, which can affect the performance of electronic devices. To overcome this problem, a prototype of a three-phase AC voltage regulator circuit was made by adjusting the SCR triggering delay angle using an analog electronics equipment control that can be used for three-phase motor soft start applications in a palm oil factory. This prototype will be used as a learning tool for the practical for Aceh Polytechnic students for power electronics courses. This system is built with a method where the three-phase source is first lowered using a transformer arranged in a star on the primary and secondary sides, then each voltage is compared to the ground using an IC LM324, which aims to produce pulses wave. This pulse then connected to a triangular wave generator circuit, this triangular wave is then compared with the DC source voltage from the potentiometer, which aims to regulate the SCR triggering angle of SCR via MOC3063 driver, where the load used is resistive and connected in a star. The measurement using an oscilloscope and observing the change of triggering angle for several variations of each phase, the different Vrms voltage between measurements compared to mathematical analysis influenced by several factors, including, the transformer is made of three transformers that not identically, the electronic components used are not in ideal condition, and observations on the oscilloscope are carried out visually using the eye and manually adjusting the potentiometer rotation, It allows errors in observing the triggering angle of the voltage wave on the oscilloscope, while the average difference between measurements and calculations in this research did not exceed 0.6 volts.

Copyright © 2024 by the Authors.

## I. Introduction

In general, palm oil processing factories, from fresh fruit bunches to Crude Palm Oil (CPO), require three-phase electric motors to drive, move, or rotate them. The problems that often arise when using three-phase electric motors simultaneously in large numbers will result in very large surges in the electric current, which can affect the performance of electronic devices in the system. One of the subject courses that must be taken by students of the electronics technology study program at Aceh Polytechnic is the power electronics course, with one of the sub-topics being alternating current voltage regulators. In order for students to better understand the application of the AC voltage regulator sub-material, the author created a teaching aid that also serves as a prototype, namely, a soft start for a three-phase AC motor using analog electronic equipment control that can be used in a palm oil factory, which will be used as a learning tool for the practical course of power electronics. This practical module for the three-phase AC voltage regulator circuit is designed by adjusting the SCR trigger delay angle using an analog electronics circuit that can be used for three-phase motor



soft start applications. The three-phase source used has a low voltage so that students can observe the system output waveform on the oscilloscope in detail and provide a sense of safety during practice.

**II. The Proposed Method**

**2.1 Basic Concept of AC Voltage Regulator**

The basic concept of an AC voltage regulator power circuit is shown in Figure 1, where the components that used are Thyristors (SCR) which arranged in parallel back to back, SCR 1 (T1) will be controlled when the signal is on the positive side by using the  $ig_1$  pulse, while SCR 2 (T2) will be used to control the voltage on the negative side by using the  $ig_2$  pulse as shown in Figure 2(a), output of this circuit can be seen in Figure 2(b), where the positive and negative sides have symmetrical waveforms The basic concept of an AC voltage regulator power circuit is shown in Figure 1, where the components that are used are thyristors (SCR), which are arranged in parallel back to back. SCR 1 (T1) will be controlled when the signal is on the positive side by using the  $ig_1$  pulse, while SCR 2 (T2) will be used to control the voltage on the negative side by using the  $ig_2$  pulse, as shown in Figure 2(a). The output of this circuit can be seen in Figure 2(b), where the positive and negative sides have symmetrical waveforms [1]–[7].

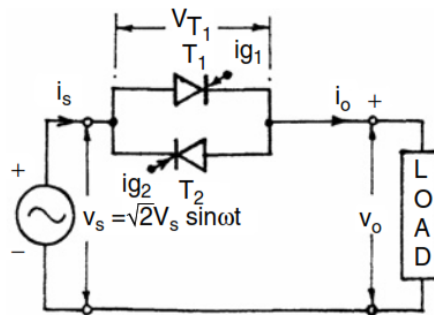

Fig. 1. AC voltage regulator power circuit

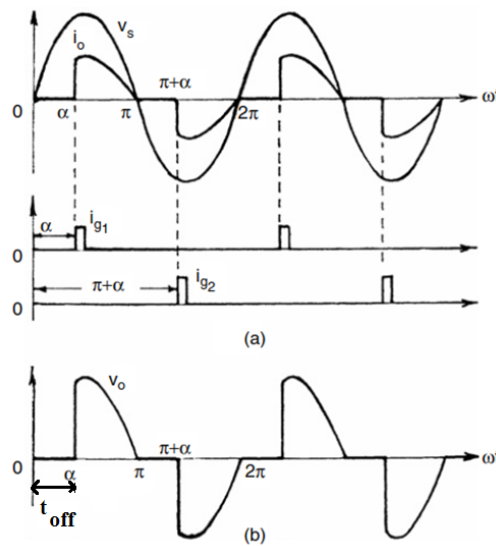

Fig. 2. (a) Input waveform & trigger pulse, (b) Output wave

The output voltage in Figure 2 (b) can be calculated by using equations (1) and (2), the output voltage ( $V_o$ ) or  $V_{rms}$  voltage can be varied by adjusting the triggering angle ( $\alpha$ ) from  $0^\circ$  to  $180^\circ$  degrees. The power circuit in this research uses 6 SCRs that are connected to a three-phase voltage source and resistive load, as shown in Figure 3.

$$V_o = \left[ \frac{1}{\pi} \int_{\alpha}^{\pi} 2V_s^2 \sin^2 \omega t d(\omega t) \right]^{1/2} \tag{1}$$

$$V_o = V_s \left[ 1 - \frac{\alpha}{\pi} + \frac{\sin(2\alpha)}{2\pi} \right]^{1/2} \tag{2}$$

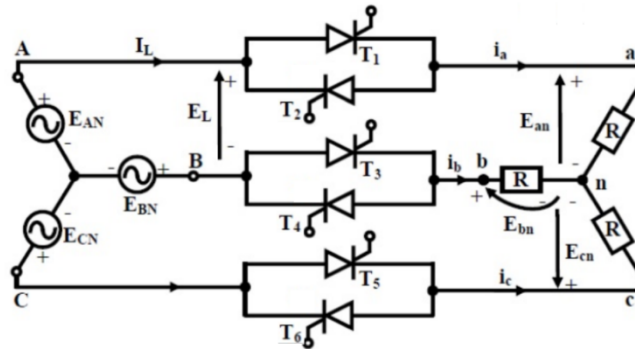

Fig. 3. Three phase AC Voltage regulating circuits.

A three-phase power supply source is a type of alternating current (AC) commonly used in the generation, transmission, and distribution of electricity. Three-phase electricity is a type of polyphase system that uses three or four cables with a neutral. In three-phase power, the voltage on each wire has a phase shift of 120° relative to each of the other wires, as shown in Figure 4, where each phase can be expressed by equations (3), (4), and (5) [1]–[3], [8].

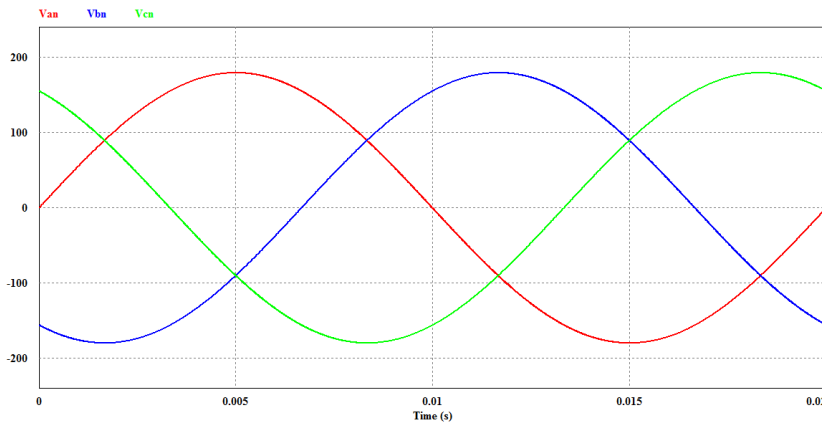

Fig. 4. Three phase wave

$$V_{an} = V_m \sin(\omega t) \tag{3}$$

$$V_{bn} = V_m \sin\left(\omega t - \frac{2\pi}{3}\right) \tag{4}$$

$$V_{cn} = V_m \sin\left(\omega t + \frac{2\pi}{3}\right) \tag{5}$$

**2.2 System Block Diagram**

This proposed research, with the title Design and application of a prototype soft start of a three-phase AC motor with analog electronic control, was constructed by using analog electronic components, in general, it can be divided into several block diagrams as shown in Figure 5 below.

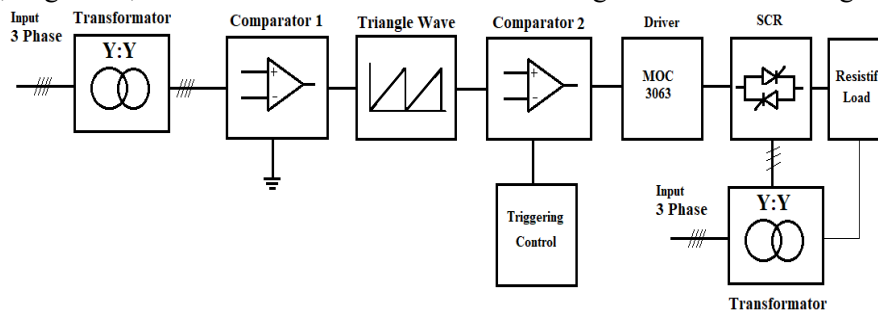

Fig.5. System block diagram

### Three Phase Step Down Transformer

The specification of the transformer that was used in this research was built by using 1 Ampere step-down transformers, which amount to three pieces. This mattered because it was difficult to find three-phase transformers with low voltage output on the market. The secondary and primary sides of this transformer are connected in a star (Y) connection as shown in Figure 6. This is needed because the system requires a low-voltage, three-phase power source that is used as a reference voltage as well as a supply source for the system's power circuit.[8] [9].

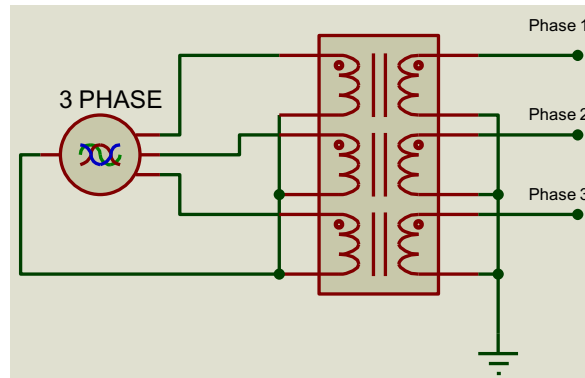

Fig. 6. Y:Y step down transformer

### Comparator Circuit 1

The comparator circuit 1 in this research was built by using the IC LM324 as shown in Figure 7, where this system uses a DC power supply of  $\pm 12$  volts. This comparator functions to compare voltage waves in phase 1, phase 2, and phase 3. For each phase, it requires two Op-amp gates. The output of this circuit will produce two different pulses for each phase, these pulses are furthermore connected to a triangle wave generator circuit [7][10].

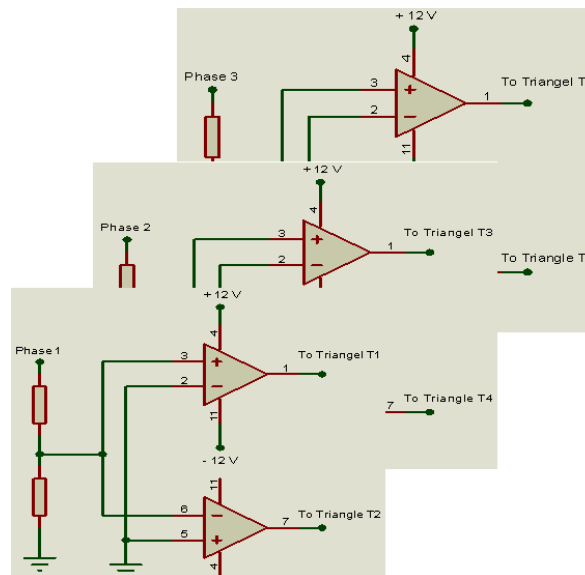

Fig. 7. Comparator circuit 1

### Triangle Wave Generator Circuit

The output produced from comparator circuit 1 for phase 1, phase 2, and phase 3 is furthermore connected to a triangle wave generator circuit composed of several electronic components, as shown in Figure 8. The output of this circuit is in the form of a triangle wave, which is then connected to comparator circuit 2[8].

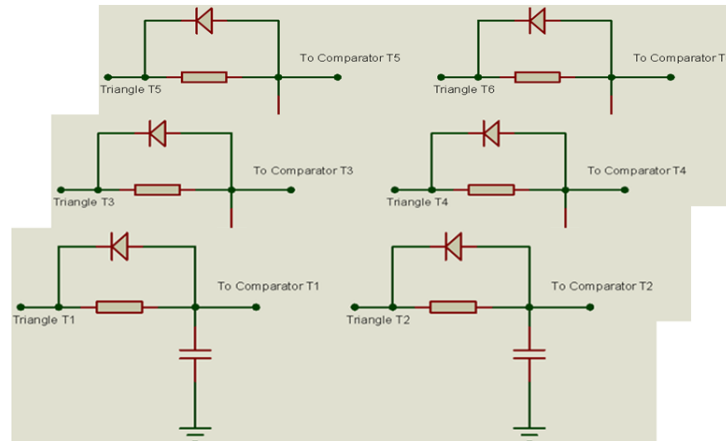

Fig. 8. Triangle Wave Generator Circuit

**Comparator Circuit 2**

This comparator circuit 2 is used to compare the triangle wave with the DC voltage, which results from the change in adjustable rotation of the potentiometer as shown in Figure 9. The change of voltage on the potentiometer is used to regulate the trigger pulse delay angle (tiggering control) of the SCR circuit, furthermore, output from this circuit is then connected to the driver circuit, which uses the MOC 3063 component.

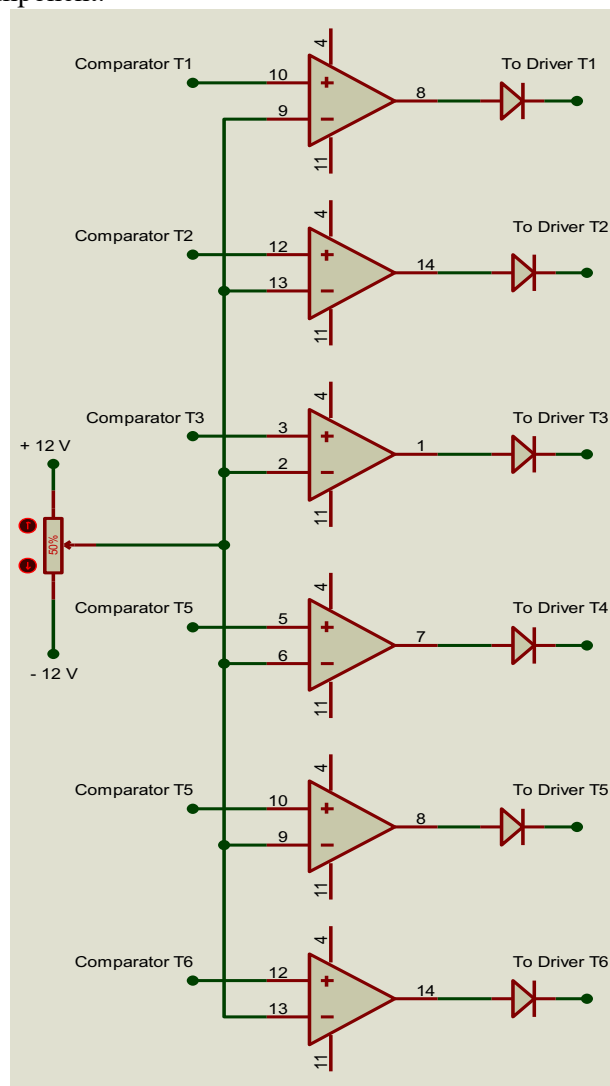

Fig. 9. Comparator circuit 2

**Driver Circuit**

The drive circuit is constructed by using six MOC 3063 components, where the input voltage from side of comparator 2 is pulses that can be adjusted with a DC voltage source, meanwhile, on the output side of MOC is used to drive the SCR gate by using an alternating current voltage source that taken from each phase but it must be through a diode component to be rectified as shown in Figure 10[11].

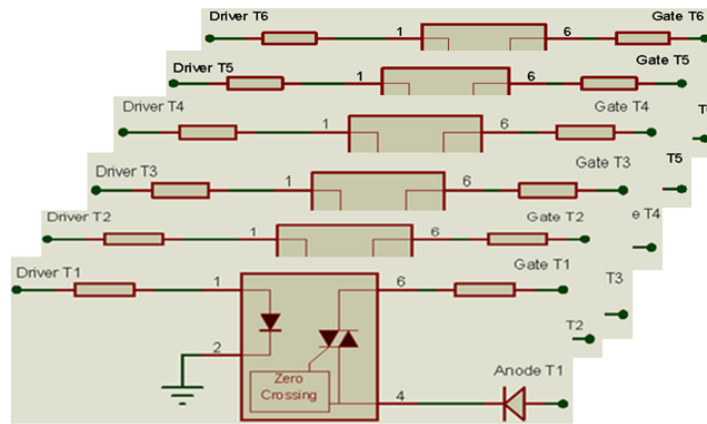

Fig.10. Driver circuit

**Three Phase Power Circuit**

The three-phase power circuit on the load side is designed by using six SCRs arranged in back to back (anti-parallel) for each phase as shown in Figure 11, where the load that used is resistive and arranged in a star connection (Y) [4].

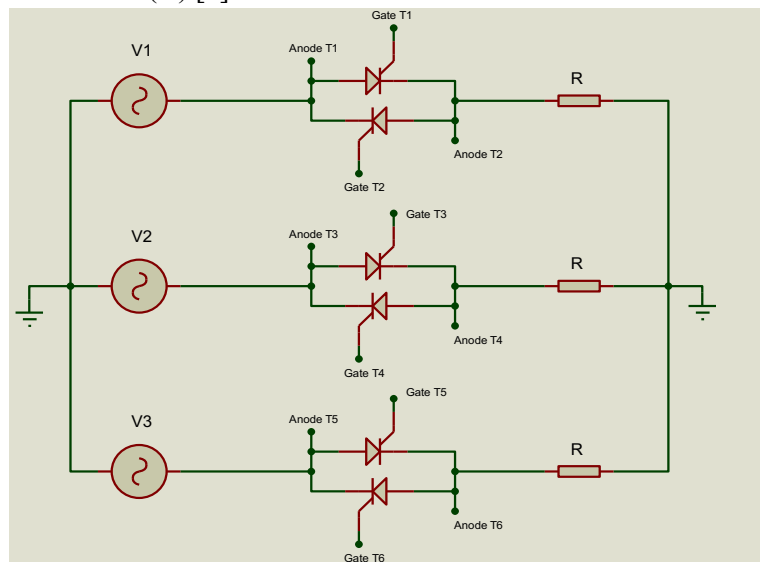

Fig. 11. Three phase power circuit

**III. Results and Discussion**

The testing circuits in this research were carried out in several stages, that is, gradual testing on the control circuits consisting of testing on the step-down transformer, on comparator circuits, on triangle wave generator circuits, and testing on power circuits that use SCR components.

**3.1 Testing On Step Down Transformer Circuit**

The three-phase output waveform in a transformer circuit, which is arranged in a Y connection, can be seen in Figure 12, where the maximum voltage from each secondary side source of the transformer has a non-identical value. The measurement results obtained by using an oscilloscope for the maximum voltage of each phase are  $V_{an} = 19.2$  Volts,  $V_{bn} = 18.4$  Volts, and  $V_{cn} = 18.0$  Volts.

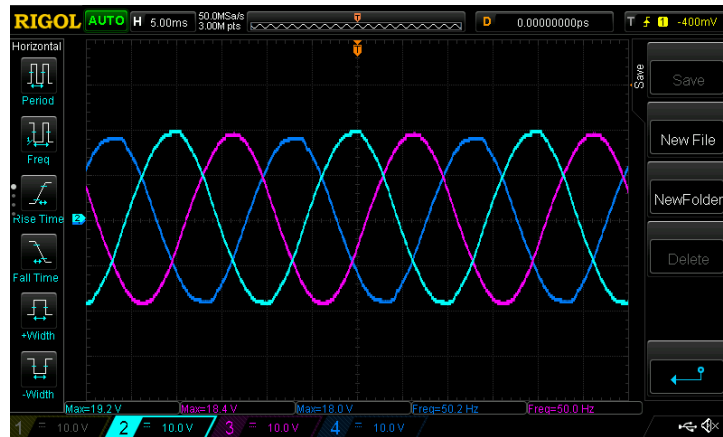

Fig. 12. Three phase step down transformer output waveform

**3.2 Comparator Circuit 1 Testing**

Measurements on comparator circuits 1 are carried out separately into three parts consisting of testing on phase 1, phase 2, and phase 3. The waveform of the measurement results in phase 1 where the circuit that used is as in figure 7 can be seen in figure 13, comp1 is the waveform of the comparator output on the positive side while comp2 is the waveform of the comparator output on the negative side of phase 1, the waveforms in phases 2 and 3 have the same pattern as phase 1.

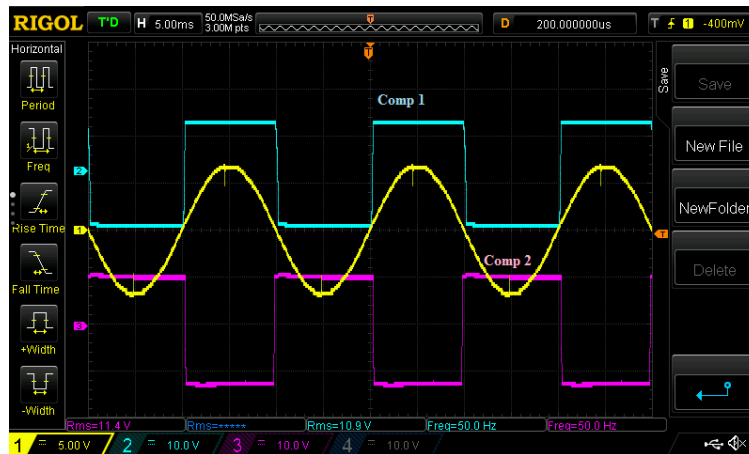

Fig.13. Waveform in 1 phase comparator circuit 1

**3.3 Triangular Wave Generator Circuit Testing**



Fig. 14. Triangle waveform at phase 1

The waveform that produced by comparator circuit 1 furthermore used as input for the triangle wave generator circuit. The output waveform that produced by the circuit in Figure 8 can be seen in Figure 14. The comp1 wave is then converted into a triangle wave (triangle 1) and the comp2 wave becomes a triangle wave (triangle 2) for phase 1. The triangle 1 wave furthermore connected to the comparator T1 and triangle 2 will be connected to the comparator T2, and the same method are used for phases 2 and 3, it will produce the same waveform one with another.

### 3.4 Comparator Circuit 2

Comparator circuit 2 is used to produce a pulse shape that can be adjusted according to changes of voltage value in the potentiometer, changes in the pulse width of each comparator (duty cycle) represent the cutting angle (trigger angle) of each SCR, in figure 15 (a) shows the trigger angle cutting pulse on the side of SCR 1 (T1) and SCR 2 (T2) where the starting point reference of the angle used comes from the phase 1 voltage source. Figure 15(b) shows the trigger angle cutting pulse on the SCR 3 (T3) and SCR 4 (T4) sides with the reference point used coming from the phase 2 voltage source, while Figure 15(c) shows the trigger angle cutting pulse on the SCR 5 (T5) and SCR 6 (T6) sides where the starting point reference angle used comes from the phase 3 voltage source. The trigger pulses of each SCR must not overlap one with another, this can be proven as the measurement results in Figure 15(d) where the trigger pulses for T1, T2, T3, and T4 do not overlap one with another, this process can occur because the reference source used comes from a three-phase source that has a phase angle difference of  $120^\circ$  between one and the other.

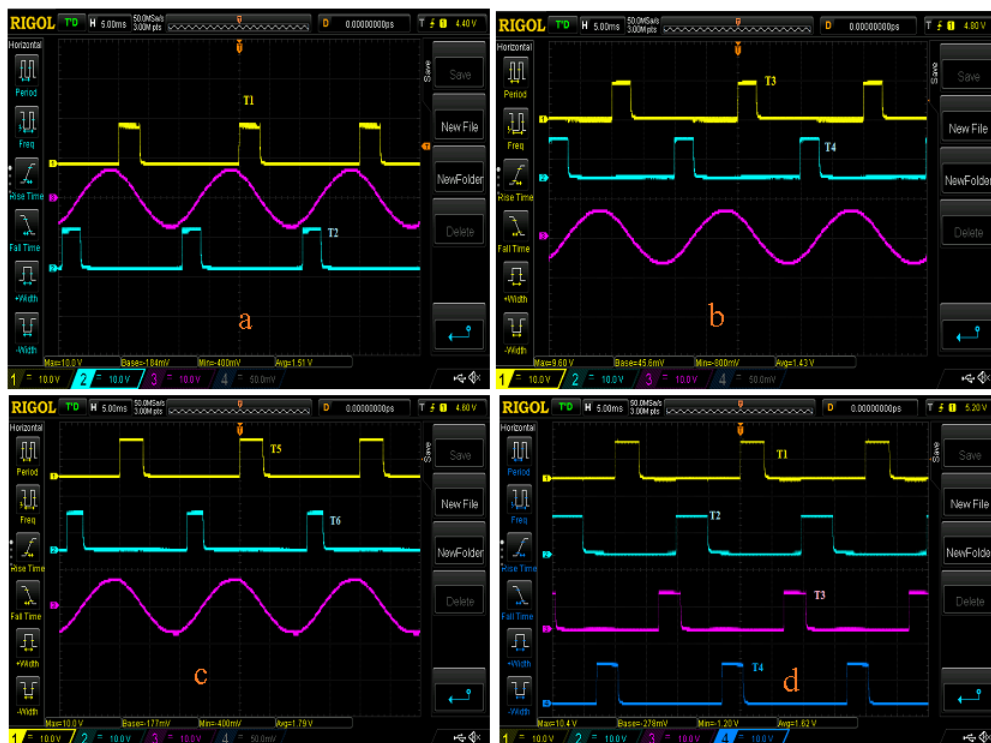

Fig.15. SCR trigger pulse wave

### 3.5 Testing On Power Circuits With Resistive Loads

Testing on the power circuit aims to see the characteristics of the output wave produced on a resistive load and arranged in a star connection, the power circuit can be seen in Figure 11, for the three-phase voltage source to be controlled that have the maximum voltages not identical as shown in Figure 16, this is because the transformers were designed did not have identical characteristics.

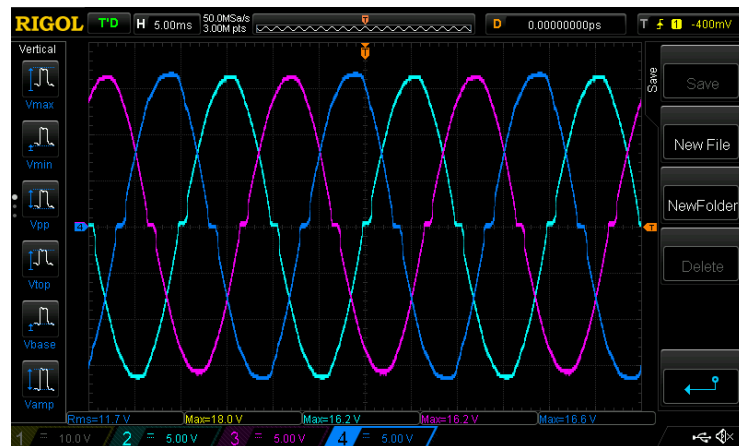

Fig.16. Three phase input waveform at load

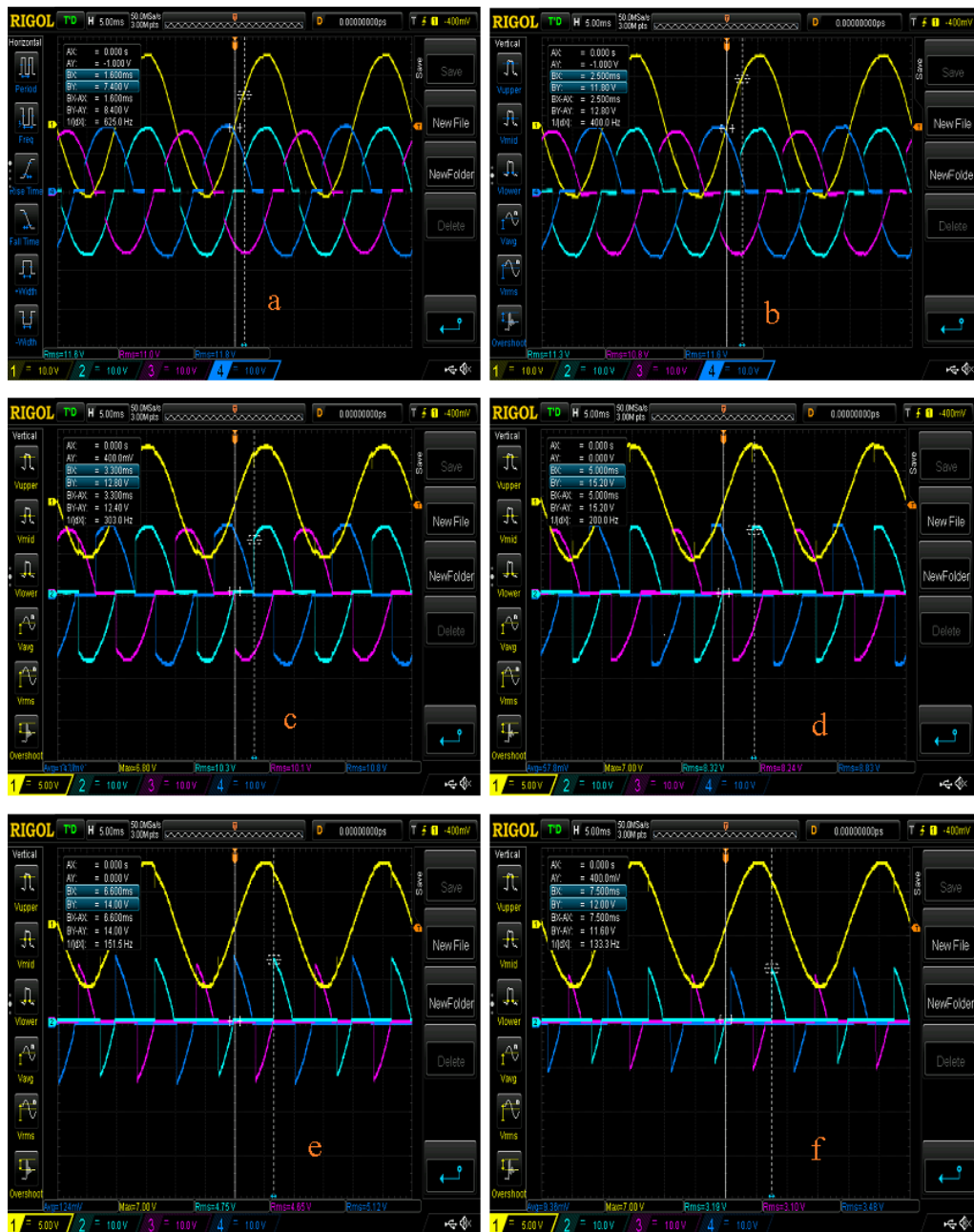

Fig. 17. Measurement waveform on load with Oscilloscope

The trigger angle cutting is done manually by adjusting the potentiometer rotation and observing the output wave cutting changes according to the time changes on the x-axis or (Ax-Bx) on the oscilloscope. The waveform of the measurement results on the resistive load can be seen in Figure 17(a) to Figure 17(f), the measurement results and calculations that using the formula and the differences can be seen in Table 1.

Table 1. Measurement results on resistive load

Toff (mS )	$\alpha$ ( $^{\circ}$ )	Input Vmax(Volt)			Vo Output Osc (Volt)			Vo Output Calc (Volt)			$\Delta$ Vo (Volt)		
		Va	Vb	Vc	Van	Vbn	Vcn	Van	Vbn	Vcn	Van	Vbn	Vcn
1,6	28,8	16,2	16,2	16,6	11,6	11	11,8	11,8 3	11,8 3	12,0 8	0,23	0,83	0,28
2,5	45	16,2	16,2	16,6	11,3	10,8	11,6	11,4 9	11,4 9	11,7 4	0,19	0,69	0,14
3,3	59,4	16,2	16,2	16,6	10,3	10,1	10,8	10,7 5	10,7 5	10,9 8	0,45	0,65	0,18
5	90	16,2	16,2	16,6	8,32	8,24	8,83	8,1	8,1	8,3	0,22	0,14	0,53
6,6	118, 8	16,2	16,2	16,6	4,75	4,65	5,12	5,35	5,35	5,25	0,6	0,7	0,4
7,5	135	16,2	16,2	16,6	3,19	3,1	3,48	4,16	4,16	4,3	0,97	1,06	0,82

### 3.6 Discussion

The measurement results using equipment in the form of an oscilloscope and observing changes in the SCR delay/triggering angle for several angles according to the Toff value for each phase can be seen in table 1. Based on the table, it can be observed that the large change in the SCR triggering angle will produce a different rms voltage (Vrms) between measurements using an oscilloscope (Osc) compared to using analysis using mathematical calculations (Calc). The difference in output voltage between phase 1, phase 2, and phase 3, is influenced by several factors including, the transformers that used are not identical, this is because the three-phase transformer in this research is made of three transformers arranged in a star connection where the windings between one transformer and another are not the same so that they produce different voltages, the electronic components used are not in ideal condition so that they produce different outputs even though the values listed on the physical are the same, other errors can occur because observations on the oscilloscope are carried out visually by using the eye and manually adjusting the potentiometer rotation so that the level of measurement accuracy between one person and another will produce different values, In this research, the difference in measurements and mathematics was 0.14 to 1.06 volt.

## IV. Conclusion

In general, the prototype circuit of a three-phase AC motor soft start with analog electronic control as a teaching aids for power electronics practicum where the load that used is resistive and connected in a star in generally workable, where the average output voltage on load measurements by using an oscilloscope compared to mathematical analysis does not have too much difference, the first step that must be taken to make measurements using an oscilloscope is to determine the toff value for each angle, then adjust the potentiometer on the comparator circuit 2 so that the output wave has a toff on the oscilloscope according to the calculations made, because the determination of the triggering angle is still manually then the measurement results of one person with another person can be different this is due to the level of accuracy in observing the oscilloscope, on the other hand the components that used are not in ideal condition so that differences in measurement results are possible.

## References

- [1] M. H. Rashid, *Power electronics and applications*, Fourth Edi. Edinburgh Gate: Pearson, 2014. doi: 10.1109/pedstc.2014.6799390.
- [2] M. D. Singh and K. B. Khanchandani, *Power electronics*, Second Edi. New Delhi: Tata McGraw-Hill

- publishing company limited New Delhi, 2007.
- [3] D. Hart W, *Power Electronics*. New York: McGraw Hill Companies, 2011.
- [4] Z. Zhang, "Design of alternating current voltage-regulating circuit based on thyristor: Comparison of single phase and three phase," *Meas. Control (United Kingdom)*, vol. 53, no. 5–6, pp. 884–891, 2020, doi: 10.1177/0020294020909123.
- [5] H. A. Ashour and R. A. Ibrahim, "Comparison analysis of AC voltage controllers based on experimental and simulated application studies," *2006 Int. Conf. Comput. Eng. Syst. ICCES'06*, pp. 79–84, 2006, doi: 10.1109/ICCES.2006.320429.
- [6] B. P. Ganthia, L. Ray, P. Senapati, and S. K. Barik, "Simulation of three phase voltage controlled soft switching start of induction motor drive," *Int. J. Recent Technol. Eng.*, vol. 8, no. 3, pp. 8104–8116, 2019, doi: 10.35940/ijrte.C6441.098319.
- [7] P. V. V Patel, S. S. Kulkarni, R. V Shirsath, and K. S. Patil, "Soft Start for 3-Phase-Induction Motor," *Int. J. Adv. Manag. Technol. Eng. Sci.*, vol. 8, no. Iii, pp. 1245–1250, 2018, [Online]. Available: [https://www.ijamtes.org/gallery/50\\_mar\\_iamtes\\_-342.pdf](https://www.ijamtes.org/gallery/50_mar_iamtes_-342.pdf)
- [8] E. Effendi and F. Fitriady, "Design and Application SCR Trigger Circuit for Three-phase Half-wave Controlled Rectifier with Resistive Load," *Inov. Teknol. dan Rekayasa*, vol. 8, no. 2, pp. 246–256, 2023, doi: 10.31572/inotera.Vol8.Iss2.2023.ID249.
- [9] S. A. S. Alkadhim, "Three Phase Transformer: Connection and Configuration," *SSRN Electron. J.*, no. July, 2020, doi: 10.2139/ssrn.3647143.
- [10] M. D. Ovais, M. Aslam, M. Shariqazhar, and N. K. Pal, "SCR based Triggering Method for Single Phase Induction Motor," *J. Emerg. Technol. Innov. Res.*, vol. 3, no. 5, pp. 104–107, 2016, [Online]. Available: <https://www.jetir.org/papers/JETIR1605021.pdf>
- [11] Onsemi, "6-Pin DIP Zero-Cross Triac Driver Optocoupler (600 Volt Peak) MOC3063M.," *Onsemi.com*, 2022, [Online]. Available: <https://www.onsemi.com/pdf/datasheet/moc3163m-d.pdf>